

Industrial Electrolytic Conductivity Cells

Specification

Main Overview

The specification of an Electrolytic Conductivity Cell requires careful consideration of the following factors:

1. Appropriate Cell Constant, determined by the analyzer or recorder used. See instrument range table.
2. Chemical resistance.
3. Physical nature of mounting; insertion, immersion, flow through, removable insertion and laboratory type.
4. Pressure rating required.
5. Integral automatic temperature compensator. Determined by the analyzer or recorder used. See instrument range table under electrolytic conductivity Reference Section if 7082 is not used.

Appropriate Cell Constant - Reference Information

The choice of cell constant is determined by the measuring instrument and its range.

What is a cell constant? The cell constant describes the cell's geometry. It is the length between electrodes divided by the effective sample area between them. The standard 1 cm^{-1} constant cell can be visualized as 2 plates of 1 cm^2 area spaced 1 cm apart. Other cell constants have different length/area ratios.

Applying the cell constant to the measured resistance/conductance converts it to resistivity/conductivity - a property of the fluid independent of the measuring apparatus and sample size.

Why a variety of cell constants? A variety of cell constants is needed to measure the complete range of electrolytic solutions from less than

1.0 ohms-cm to 18 megohms-cm. For accuracy, the measured resistance must be at a level that will give the best sensitivity for the measuring circuit. At very low measured resistance polarization effects and leadwire resistance could affect accuracy. This is avoided by choosing a cell constant which will raise the measured resistance to an acceptable level. At very high resistance values, leadwire capacitance can affect the accuracy. This is avoided by selecting a cell that will lower the measured resistance to an acceptable level.

To measure high purity water, a low cell constant is specified which lowers the measured resistance. Conversely, sulfuric acid may have a specific resistance of 1.0 ohm-cm; therefore, a 50 constant cell should be used to raise the measured resistance to 50 ohms.

Hazardous Locations

All industrial electrolytic conductivity cells manufactured by Honeywell meet requirements for Class 1, Div. 2, Group A, B, C and D for operation in hazardous locations. Div. 1 requirements of intrinsic safety are met with the 7079-17 Transmitter and Barriers.

Selection Guide for Conductivity Cells and Compensators

4973 Newest cell in conductivity line - should be quoted whenever possible for constants 0.01 to 10 cm^{-1} .

When measuring deionized water where the cell has the potential of being exposed to regeneration acids and bases, the 4973 Cell with its titanium electrodes and rapid temperature response are preferred. If a 4905 Cell is used, the platinum electrodes are best,

but the nickel electrodes are suitable (and should be bid in a competitive situation.)

4905 Widest choice of cell constant - should be quoted on all applications where 4973 is not applicable and for replacements.

4909 Should be quoted when cell removal is required without disturbing the process.

4800 Series Should be quoted for concentrated sulfuric acid, and other strong acid or base applications where the 4973 or 4905 type cells are not compatible because of corrosion resistance.

Physical Nature of Mounting

Proper mounting of a cell is as important as any other parameter. A cell improperly installed may not give an accurate indication of the true process conditions. Careful consideration should be given to the mounting.

Insertion Cell can be mounted directly in process stream. Location should be in rapid fluid motion and in a position which will prevent sediment accumulation. Also suitable for lab use.

Immersion Cell can be mounted over a tank or open trough. The cell should be completely immersed to avoid a false indication of high resistance (low conductivity) or incomplete temperature compensator immersion.

Flow Cell assembly can be placed directly in process fluid line or bypass sample line. The cell should be completely immersed and positioned to prevent accumulation of sediment to avoid false indication of high resistance (low conductivity).

Removable Cell can be removed at pressures 50 psi or less without disturbing the process.

4973 and 4974 Series Overview

These cells are ruggedly constructed for reliable, continuous measurement of electrolytic conductivity in industrial water processes at temperatures up to 140°C at pressures up to 250 psig.

The cells feature polyethersulfone (PES) construction for high-corrosion resistance, with electrodes of titanium (for 0.01 and 0.1 cell constants) or high-density graphite (for 1.0 and 10.0 cell constants).

For *insertion* applications, the 3/4" NPT male thread permits permanent installation in a pipe or tank; the cell can also be used as a laboratory dip-type for batch sampling.

For *flow* applications, the cell can be installed directly into a process stream, or used with a separately ordered 3/4" pipe tee in a by-pass stream. The cells have been

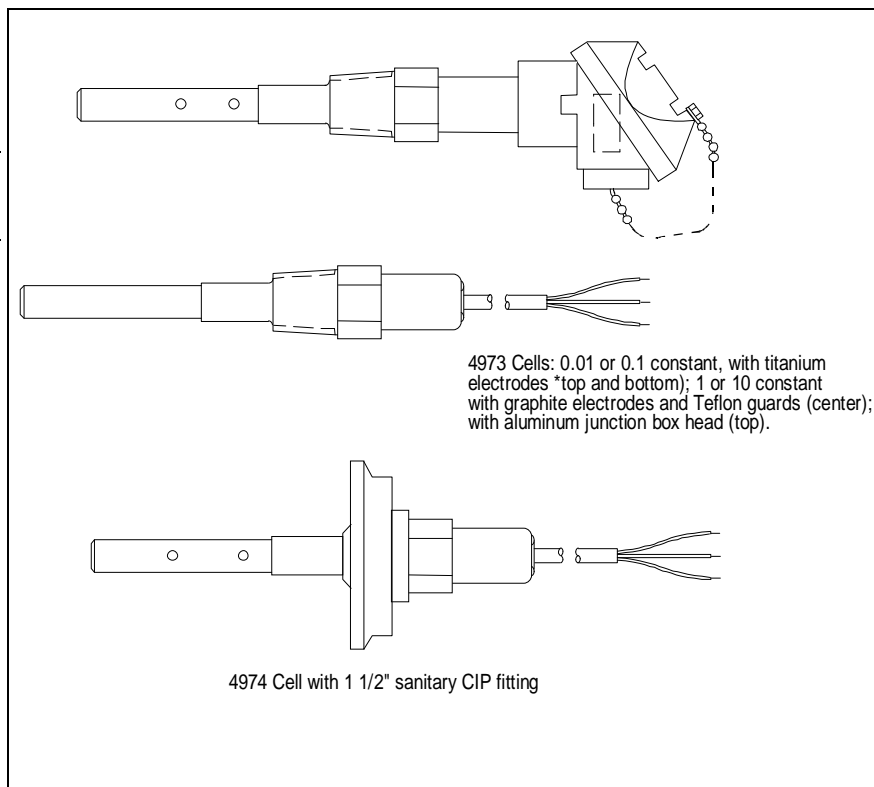

designed to keep the electrodes and the temperature compensator immersed in the stream flow, ensuring that the cell will respond quickly and accurately to changes in both solution concentration and temperature.

For *sanitary clean-in-place (CIP)* piping systems, the 4974 cells include standard 1 1/2" or 2" CIP fittings suitable for food and beverage, pharmaceutical and cosmetic, or biotechnology industries.

Specifications

4973/4974	
Automatic Temperature Compensator	Supplied on all cells
Cell Constant	0.01, 0.1, 1.0, and 10 cm ⁻¹
Maximum Temperature Limit	4973: 140°C (284°F) at rated pressure 4974: 130°C (266°F) at rated pressure, may be further limited by CIP gasket and clamp type
Maximum Pressure Limit	4973: 1724 kPa (250 psig) at rated temperature 4974: 1034 kPa (150 psig) at rated temperature, may be further limited by gasket and clamp type
Insertion	4973 cells: 3/4" NPT male thread for schedule 40 and 80 pipe 4974 cells: 1 1/2" or 2" sanitary CIP fitting
Insertion Depth	89 mm (3 1/2") for 1, 10, and 0.01 constants from solution end of 3/4" NPT male thread 64 mm (2 1/2") for 0.1 constant

Specifications

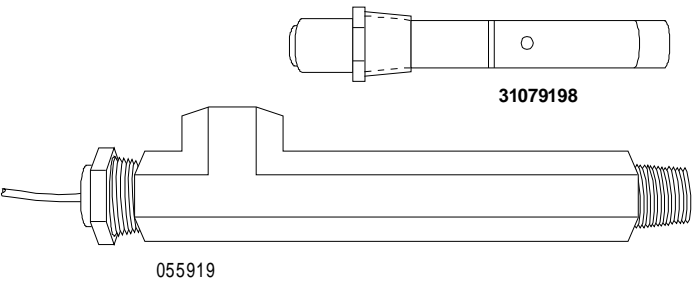
Wetted Parts	Cell body: PES (polyethersulfone) Electrodes: 0.01 and 0.1 constant, titanium; 1.0 and 10.0 constant, high-density graphite with Teflon guard. 4974 series also includes food grade silicone rubber and polished 316 s.s.
Electrical Connections	Integral PVC-covered nonshielded 18-gage cable, 2.1 m (7') or 6.1 m (20') long, as specified. If more than 20' are required, specify the junction box head and the required length of extension cable (head has 1/2" NPT conduit connection). For a separate junction box, specify part number 31316260, and appropriate length of cable.
Weight	4973: 0.2 kg (0.5 lb.) 4974: 0.4 kg (1 lb.)
<p>Flow Chambers for 4973</p>  <p>Flow Chambers (ordered separately) used with 4973 Cell for Sample Stream Measurements</p>	
055919	Max. flow: 5 gpm at 40 psig Material: PES Max. Pressure: 200 psig at 25°C Max. Temperature: 140°C at 5 psig Dimensions: 38 mm x 222 mm (1 1/2" x 8 1/4") Sample Inlet: 3/4" NPTM Sample Outlet: 3/4" NPTF Cell Port: 3/4" NPTF
31079198	Max. flow: 750 cc/min. Material: 316 stainless steel Max. Pressure: 200 psig (1378 kPa) Max. Temperature: 140°C Dimensions: 38 mm (1 1/2") dia. X 114 mm (4 1/2") Sample Inlet: 1/8" NPTF Sample Outlet: 1/8" NPTF Cell Port: 3/4" NPTF

4905 Series Cells Overview

Constructed of PES for high corrosion resistance, 4905 Series cells can be supplied with either nickel or platinum electrodes, and will provide continuous reliable measurements at temperatures up to 140°C at pressures up to 250 psi.

For insertion applications, the 1" NPT male thread permits installation in a pipe or tank, for flow applications, the cell can be installed directly into a process stream, or used with a separately ordered 276127 Flow Chamber in a bypass stream.

For immersion applications, ½" rigid or flexible plastic pipe can be threaded into the top of the cell: up to 6' (1.8m) for a 7' cable, up to 19' (5.8m) for the 20' cable.

Specifications

4905 Series Cell	
For high corrosion resistance, the 4905- and 4909-Series Cells can be supplied with either nickel or platinum electrodes.	
Application for 4905 Series Cell	
Insertion	The 1" NPT male thread permits installation in a pipe or tank; the cell can also be used as a laboratory dip-type for batch sampling.
Immersion	1/2" rigid or flexible plastic pipe can be threaded into the top of the cell. Up to 1.8 m (6') for the 7' cable, up to 5.8 m (19') for the 20' cable.
Flow	The cell can be installed directly into a process stream, or used with a separately ordered 276127 Flow Chamber in a bypass stream.
Specifications for 4905 Series Cell	
Cell Constants	0.01, 0.1, 1.0, 5, 10, 20, 25, and 50 cm ⁻¹
Electrode Material	Nickel or platinum, as specified. Constants 5 and higher are platinized.
Leadwire	Tefzel-covered 18-gage cable 7' or 20' long, as specified in Table IV. If more than 20' is required, select either the cast aluminum junction box head option in Table IV or select the 20' option in Table IV and the separate 31316260 cast iron junction box and additional length of leadwire as necessary.
Electrical Connections	3 or 4 leads when integral Automatic Temperature Compensator is selected, 2 leads without A.T.C.
Pressure	250 psig @ 140°C (284°F) maximum
Temperature	140°C (284°F) maximum continuous (the temperature limit for the A.T.C. accuracy may be lower than the cell's material-of-construction temp. limit).
Mounting	1" NPT male
Insertion Depth	114 mm to 175 mm (4.5" to 6.9") depending on cell constant; 112 mm or 224 mm (4.4" or 8.8") additional depth available on special order.
Overall Length	Approximately 152 mm to 203 mm (6" to 8") without junction head. Approximately 254 mm to 311 mm (10" to 12 1/4") with junction head.
Wetted Materials	Cell: polyethersulfone Electrodes: Nickel or platinum
Weight	Approximately 0.45 kg (1 lb.)

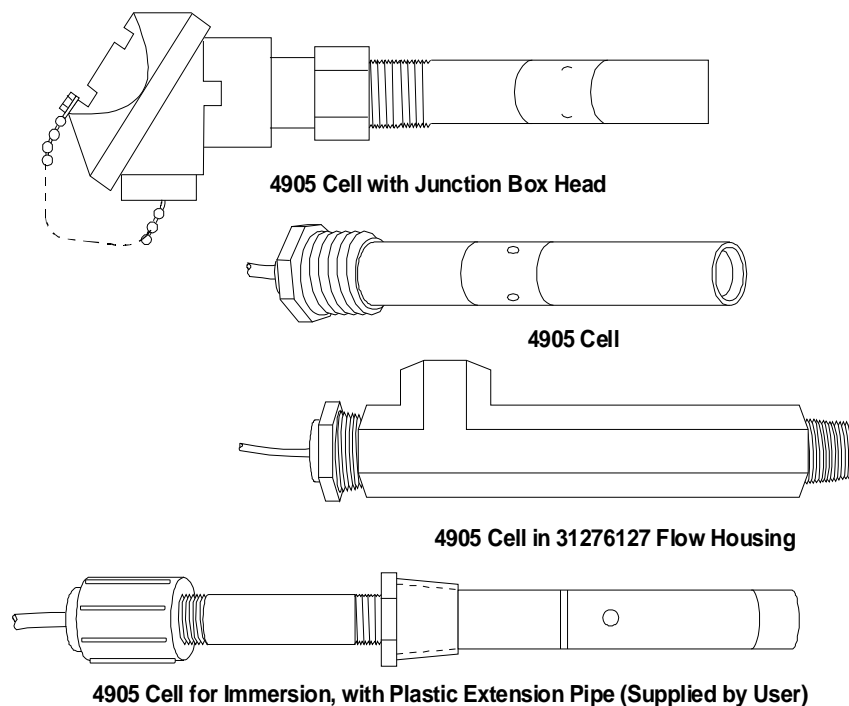

Specifications for 276127 Flow Chamber

Pressure	200 psig maximum @ 25°C (77°F)
Temperature	140°C (284°F) maximum @ atmospheric pressure
Flow	2 gpm @ 40 psig and atmospheric discharge
Dimensions	38 mm (1 ½") octagon x 222mm (8 ¾") long Sample Inlet: ¾" NPTM Sample Outlet: ¾" NPTF Cell Port: 1.0" NPTF

4909 Series Cells Overview

4909 Cell Assemblies, available in 316 Stainless Steel or CPVC Plastic, allow insertion or removal of the cell without interruption to the process. Two safety features, a restraining mechanism and an internal safety

stop, provide protection to an operator for safe cell removal at pressures up to 50 psig with caution. The plastic removal device is equipped with a purge port to flush out any accumulated debris to aid in easy insertion or removal of the cell.

Specifications for 4909 Series Cell

Cell Constants	0.01, 0.1, 1.0, 5, 10, 20, 25, and 50 cm ⁻¹
Electrode Material	Nickel or platinum, as specified. Constants 5 and higher are platinized.
Leadwire	Tefzel-covered 18-gage cable 7' or 20' long, as specified in Table IV. If more than 20' is required, select either the cast aluminum junction box option in Table IV or select the 20' option in Table IV and the separate 31316260 cast iron junction box and additional length of leadwire as necessary.

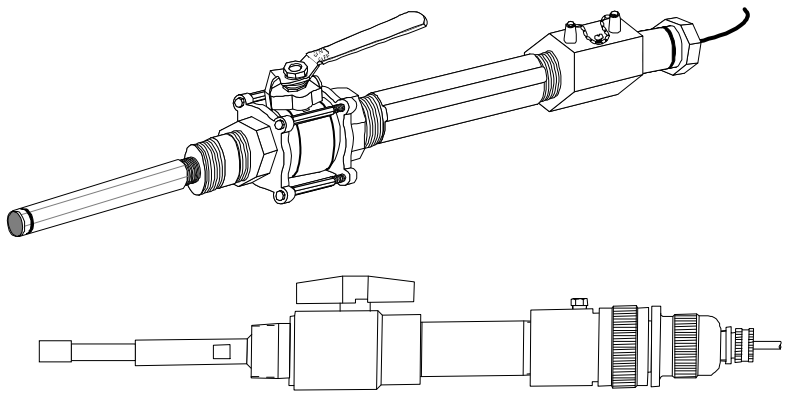
Specifications for 4909 Series Cell	
Electrical Connections	3 or 4 leads when integral Automatic Temperature Compensator is selected, 2 leads without A.T.C.
Dimensions	38 mm (1 1/2") octagon x 222 mm (8 3/4") long. Sample inlet 3/4" NPT male. Sample outlet 3/4" NPT female. Cell port 1" NPT female.
 <p>Top: 4909 SS Removal/Insertion Cell Assembly Bottom: 4909 CPVC Plastic Removal/Insertion Cell Assembly</p>	
Specifications for 4909 316 SS Assembly	
Pressure	1379 kPa (200 psig) maximum at 140°C (284°F). Maximum pressure for removal or insertion is 50 psig.
Temperature	140°C (284°F) at 200 psig
Process Connection	1 1/4" NPT male
Insertion Depth	Varies between 165 mm and 224 mm (6.5" and 8.8") from end of nipple, depending on cell constant; 112 mm (4.4") additional depth available on special order.
Overall Length	From process connection: 422 mm (16.6"); 521 mm (20.5") with junction head option
Total Length Required for Cell Removal	1130 mm (44.5"); 1238 mm (50.5") with junction head option.
Wetted Materials	316 SS ball valve, Viton & Teflon internal sealing materials, PES cell, nickel or platinum electrodes, as specified.
Weight	4.5kg (10 lbs.)
Specifications for 4909 CPVC Plastic Assembly	
Pressure and Temperature	862 kPa (125 psig) maximum @ -5°C (23°F) 621 kPa (90 psig) maximum @ 50°C (122°F) 345 kPa (50 psig) maximum @ 80°C (176°F)
Process Connection	1 1/2" NPT male
Purge Port Connection	1/4" NPT female. Purge fluid temperature and pressure not to exceed 4909 CPVC temperature and pressure specifications.
Insertion Depth	Varies between 114 mm and 173 mm (4.5" and 6.8") depending on cell constant. For 152 mm (6") additional depth, specify 074344 tube separately.
Overall Length	From process connection: 502 mm (19.7"); 564 mm (22.2") with junction head option.
Additional Clearance Required for Cell Removal	914 mm (36"); 1067 mm (42") if 074344 tube is used.
Wetted Materials	CPVC ball valve, Viton, Teflon & EPDM internal sealing materials, PES cell, nickel or platinum electrodes, as specified.
Weight	1.6 kg (3.5 lb.)

4801 and 4802 Series Cell Overview

The 4800-Series Cells feature high corrosion resistance and a rugged configuration to provide reliable continuous measurements in industrial processes. The insertion- and immersion-types are usable in process temperatures up to 125°C; flow-types are limited to 100°C and lower temperatures.

High-constant cells (5 to 50 cm⁻¹) are constructed of glass-reinforced Teflon F.E.P. Low-constant cells (0.01, 0.1, and 1 cm⁻¹) are made of PES (polyethersulfone). Electrodes for cell constants of 5, 10, 20, 25, or 50 are platinized platinum; electrodes for cell constants of 0.01, 0.1, and 1 are platinum.

All cells are supplied with integral 7' leadwires; either a PVC-covered cable (100°C, maximum) or, where applicable, Teflon-covered individual wires (125°C, maximum).

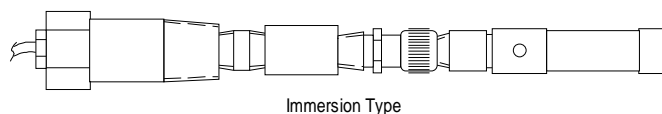
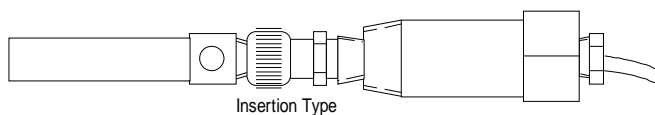

The 4801 Insertion-type has a 1" NPT male thread to permit permanent installation in a pipe or tank and is available with an integral automatic temperature compensator.

The 4802 Immersion-type is used directly in a process tank or reservoir. A 1" NPT male thread is

provided for mounting; an extension nipple, supplied by the user, determines the depth of immersion (limited by the integral 7' leadwire). An integral Automatic Temperature Compensator is available.

Specifications for 4800-Series		
Type	4801 Insertion Type	4802 Insertion Type
Maximum Temp. Limit*	125°C*	
Maximum Press. Limit	1384 kPa (200 psig)	
Electrode and Cell Body Materials	For cell constants 0.01, 0.1, and 1 cm ⁻¹ , platinum electrode, PES (polyethersulfone) body. For cell constants 5, 10, 20, 25, or 50 cm ⁻¹ , platinized platinum electrode, glass-reinforced Teflon body.	
Mounting Connection	1" NPT male thread	
Insertion Depth	For cell constants 0.01 to 5: 190 mm (7 1/2"). For cell constants 10 to 50: 203 mm (8").	Cell assembly supplied in two sections; user must supply 1/2" NPT pipe nipple to length desired.
Wetted Parts**	Carpenter 20 SS or Monel	Carpenter 20 SS
Weight (approx.)	1.3 kg (3 lb.)	
Electrical Connections	Two leads, for cell only; three leads for cell and integral ATC.	
Leadwire	Integral 18-gauge cable(s) PVC-covered (100°C max.) or Teflon-covered separate leads (125°C max.), 2.1 m (7') long. If a length greater than 7' is required, order a 31316260 Junction Box and appropriate length of 834059 cable.	

*Actual process-temperature limits are determined by Automatic Temperature Compensator selected.

**Carpenter 20 SS, for highly corrosive mineral acid solutions (except HCl); Monel, for corrosive salt solutions.

Accessory Extension Leadwire for all Cells

When Temperature Compensator suffix is 333 with *standard* range 7082 Analyzers:

Up to 500 feet: 834059 3-conductor, 18-gage cable and
835024 coaxial cable (Belden 9259)

Up to 1000 feet: 834055 4-conductor (3 used), 16-gage cable and
835024 coaxial cable (Belden 9259)

When Temperature Compensator suffix is 333 with wide range 7082 Analyzers only:

Up to 500 feet: 31834052 4-conductor, 18-gage cable

Up to 1000 feet: 834055 4-conductor, 16-gage

(Leadwire resistance compensation is provided on wide range analyzers.)

When Temperature Compensator is other than 333:

834059 3-conductor, 18-gage unshielded cable

If integral junction box is not specified, use with 31316260 junction box.

Distributor :

Industrial Automation and Control

Honeywell Inc.

In the U.S.A.: Honeywell Industrial Automation and Control, 16404 North Black Canyon HWY., Phoenix, AZ 85023, (800) 343-0228

In Europe: Honeywell S.A., 80084 Amiens Cedex 2, (33) 22.54.56.56

Honeywell Control System Ltd., Honeywell House, Bracknell, UK-RG 12 1 EB, (44) 1344 826000

In Japan: Yamatake-Honeywell Co. Ltd., Nagai Int'l Bldg., 2 - 12 - 19 Shibuya-Ku, Tokyo 150 Japan, 81-3-3486-2051

In Asia: Honeywell Asia Pacific Inc., Room 3213-3225, Sun Hung kai Centre, No. 30 Harbor Road, Wanchai, Hong Kong, (852) 829-8298

In the Mediterranean: Africa and Middle East Region, Honeywell SpA, Via Vittor Pisani 13, 20124 Milano, Italy (39-2) 67731

Honeywell Pacific Division: Honeywell Pty Ltd., 5 Thomas Holt Drive, North Ryde Sydney, NSW Australia 2113, (61-2) 353 7000

In Canada: The Honeywell Centre, 155 Gordon Baker Road, Ontario M2H 3N7, 1-800-461-0013

In Latin America: Honeywell Inc., 14505 Commerce Way, Suite 500, Miami Lakes, Florida 33016-1556, (305) 364-2300